

XFP 1-2 LOOP NETWORKABLE ANALOGUE ADDRESSABLE FIRE PANELS

Fully approved to EN54 parts 2 & 4 by the Loss Prevention Certification Board, the XFP Range of networkable analogue addressable fire alarm control panels offers high performance at a competitive price. Available in two different versions (a cost-effective single loop 16 zone panel supplied in a plastic enclosure and a robust 1 or 2 loop 32 zone metal panel), the range offers an array of user and installer-friendly features.



XFP Single Loop 16 Zone Panel



XFP 1 or 2 Loop 32 Zone Panel



Key Features

- ▶ Third-party certificated to EN54 parts 2 and 4 by the LPCB.
- ▶ Full compatibility with the Context Plus range of smoke and heat detectors, call points, sounders and control modules.
- ▶ The ability to inter connect up to eight XFP main panels (any variant) plus an additional four XFP repeater panels per main onto a two wire RS485 network.
- ▶ Two independently programmable conventional sounder circuits.
- ▶ Two programmable inputs.
- ▶ A fault output relay and three programmable relay outputs with voltage free changeover contacts.
- ▶ Three zone dependency functions (A, B & C to EN54-2 Clause 7.12)
- ▶ A day/night (building occupied/unoccupied) function.
- ▶ An investigation delay period function.
- ▶ Individual sensitivity settings for each device.
- ▶ A phased evacuation and delays to outputs facility (to EN54-2 Clause 7.11)
- ▶ An alarm counter that records the number of times the panel has been in an alarm state (to EN54-2 Clause 7.13).
- ▶ Powerful short circuit protected loop drivers, capable of supporting up to 40 loop powered 10mA sounders per loop.
- ▶ An integral EN54 switch mode PSU rated @ 185-260V a.c. 50/60Hz (3A on 32 zone panel, 1.4A on 16 zone panel).
- ▶ Adjustable contamination levels.
- ▶ Earth fault monitoring.
- ▶ Push button access code or keyswitch entry to Access Levels 2 and 3 (depending on model purchased).
- ▶ An easy to read, 80 character back-lit display.
- ▶ 40 characters of custom text per device.
- ▶ 999 event monitoring.
- ▶ Comprehensive test facilities (to EN54-2 Clause 10) and a wide range of maintenance and commissioning functions including auto-learning loops, monitor a point, test outputs, one man walk test and loop continuity test).
- ▶ An intuitive Windows based upload-download PC program that allows the system to be programmed quickly and easily.

WHY LPCB?



The LPCB stamp of approval is recognised worldwide and demonstrates that the XFP has been tested and certified as being compliant with EN54 parts 2 and 4 by the Loss Prevention Certification Board.

A TYPICAL XFP ANALOGUE ADDRESSABLE LOOP / XFP NETWORKING DETAIL

Below is a diagram of a typical Context Plus analogue addressable loop fitted with a selection of detectors, loop powered sounders, modules and isolators, all connected to an XFP single loop 16 zone panel. The diagram also illustrates how a series of XFP main panels can be networked using the range's powerful RS485 network.

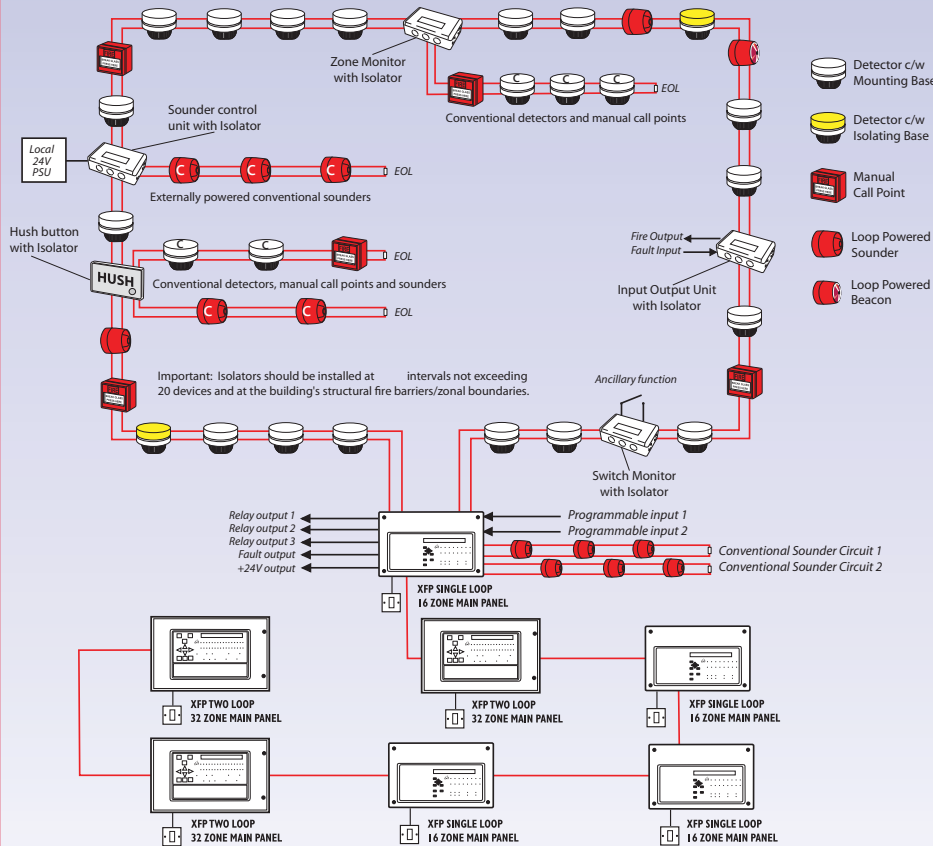

This diagram is provided for illustration purposes only and you should always refer to the relevant XFP panel/device instructions as appropriate before installation. Note that the descriptions and availability of the devices shown may not be applicable to all manufacturer's protocols.

KEY FEATURES OF THE XFP'S NETWORK PROTOCOL

The XFP's network protocol allows the interconnection of up to eight XFP main panels (any mix) over a two-wire RS485 network. Alternatively, the network can be used to connect up to eight XFP repeaters to one XFP main panel. It is not possible to mix XFP main panels and repeaters on the same network.

Key features of the XFP's network protocol when used for interconnecting XFP main panels:

- ▶ Allows the interconnection of up to eight XFP main panels (any mix of single loop 16 zone XFPs and 1 and 2 loop 32 zone XFPs)
- ▶ Up to 1 km of cable may be fitted to an XFP main panel network.
- ▶ Each networked XFP main panel can be programmed to accept Fires, Faults and Control actions such as Silence Alarm Sounders and Control Panel Reset from other main panels. They will also Accept Disablement commands for zones, sounders and output sets from other main panels.
- ▶ All panels monitor all other panels for network wiring faults.
- ▶ Fires on remote panels are displayed on local panels including the point description of the alarm's origin.
- ▶ Faults on remote panels are displayed on local panels including the point description of detectors.
- ▶ Cause and effects can be programmed into local panels dependent on which remote panel is in alarm.
- ▶ The network supports the programming of site data into remote panels from a PC at a local panel.
- ▶ Time and date is common to all panels throughout the network.
- ▶ All networked main panels require a network communication card

Key features of the XFP's network protocol when used for connecting XFP repeaters

- ▶ Allows the connection of up to eight XFP repeaters to one non-networked main panel. The XFP main panel must have a network communication card fitted.
- ▶ Up to 500m of cable may be fitted to an XFP repeater network.
- ▶ Each XFP repeater offers all the functions and controls of an XFP main panel.

XFP ORDER CODES

XFP SINGLE LOOP 16 ZONE FIRE PANELS - LPCB approved to EN54-2/4
Communication protocol = Apollo X/P95/Discovery

XFP501E/CON XFP Networkable single loop 16 zone panel
Code/keyswitch entry, c/w 1.4A psu, plastic enclosure

XFP 1 LOOP 32 ZONE FIRE PANELS - LPCB approved to EN54-2/4
Communication protocol = Apollo X/P95/Discovery

XFP501/CON XFP Networkable one loop 32 zone panel
Code/keyswitch, c/w 3A psu, metal enclosure

XFP 2 LOOP 32 ZONE FIRE PANELS - LPCB approved to EN54-2/4
Communication protocol = Apollo X/P95/Discovery

XFP502/CON XFP Networkable two loop 32 zone panel
Code/keyswitch, c/w 3A psu, metal enclosure

XFP NETWORK COMMUNICATION CARDS*

CFP761 XFP network communication card for XFP 16 zone main panels

AFP711 XFP network communication card for XFP 32 zone main panels

(One network communication card is required per networked main panel. Note that repeater panels are supplied with a network communication card already fitted).

XFP REPEATERS*

XFP510-16 XFP Networkable repeater panel, 16 zones
Code/keyswitch entry, c/w psu, plastic enclosure

XFP510-32 XFP Networkable repeater panel, 32 zones
Code/keyswitch, c/w psu, metal enclosure

XFP BEZELS & ENCLOSURES

AFP385 Flush mount bezel (for XFP 32 zone main & repeater panels)

BF359/3S Stainless steel glazed enclosure for XFP 32 zone panels, requires BF359/3CL or BF359/3SL lock kit

BF359/3CL Cam lock kit for BF359/3S enclosure

BF359/3SL Electromagnetic solenoid lock kit for BF359/3S enclosure

Note XFP 16 zone panels can be semi-flush mounted without the need for a bezel

XFP PROGRAMMING SOFTWARE*

XFP507 XFP Upload/download software kit (all protocols)
Windows 98, 2000, XP. Includes programming lead

SAF7070000 2m Programming lead ONLY

XFP PRINTER KITS*

AFP709 XFP off-board printer kit

* Repeaters, bezels, network communication cards, programming software and printer kits are not included within the scope of the XFP's LPCB approval

XFP 1-2 LOOP NETWORKABLE ANALOGUE ADDRESSABLE FIRE PANELS

XFP Technical Specifications

SINGLE LOOP 16 ZONE XFP PANELS XFP501E/CON

ONE OR TWO LOOP 32 ZONE XFP PANELS XFP501/CON XFP502/CON

Power Supply Specification

Mains supply	230V a.c. ± 10% 50/60Hz. Max current 350mA	230V a.c. ± 10% 50/60Hz. Max current 680mA
Internal power supply	27V d.c Nominal	27V d.c Nominal
Total output current limited to	1.4A @ 230V a.c.	3A @ 230 V a.c.
Supply and battery charger monitored for failure	Yes	Yes
Batteries monitored for disconnection and failure	Yes	Yes
Batteries protected against deep discharge	Yes	Yes
Max. battery size and type	3.2 Ahr VRLA	7.0 Ahr VRLA
Specified batteries for LPCB approved systems	2 x Yuasa NP3.2-12	2 x Yuasa NP7-12
Quiescent current drain (1 loop unloaded)	< 50mA	< 80mA
Quiescent current drain (2 loop unloaded)	not applicable	<100mA
Earth fault monitoring	Yes (any conductor)	Yes (any conductor)
Temperature compensated charging	Yes	Yes

Loop Driver Specification

Number of loop drivers	1	1 (XFP501/CON) 2 (XFP502/CON)
Line monitored for open and short circuit faults	Yes	Yes
Onboard loop isolators with LED indication when active	Yes	Yes
Auto-polling from each loop end	Yes	Yes
Max. loop output current	500mA (Voltage: 25V min, 34V max)	500mA (Voltage: 25V min, 34V max)
Max. number of addressable devices per loop	126	126
Max. number of loop powered sounders per loop @ 10mA	40	40
Number of programmable sounder groups	16	16
Number of programmable output sets	16	16

Conventional Sounder Circuit Specification

Number of programmable circuits	2	2
End of line resistor value	6800 ! 5% Tol. 0.25 W	6800 ! 5% Tol. 0.25 W
Line monitored for open and short circuit faults	Yes	Yes
Outputs fused at	400mA	400mA
Max. number of sounders @ 20mA	40	80

Auxiliary Outputs

Type	Relay voltage free single pole changeover	
Max switching current	1A	
Max switching voltage	30 V d.c	
Relay 1	Programmed from cause and effect	
Relay 2	Programmed from cause and effect	
Relay 3	Programmed from cause and effect	
Fault	Active when no faults are present	
24V Aux Power Output	19.5V min, 28V max. Max current 100mA. Protected by resettable overload circuit	

Auxiliary Inputs

Input 1	Connect to 0V to trigger. Max input voltage 27V d.c (non-latching). Programmable from cause and effect.
Input 2	Connect to 0V to trigger. Max input voltage 27V d.c (non-latching). Programmable from cause and effect.

Fuses (to IEC - EN60127 Pt2)

Mains Fuse	1A HRC Ceramic 20mm	1A HRC Ceramic 20mm
Battery Fuse - limits the current drawn from the battery	1.6A F 20mm	3.15A F 20mm

Panel Indicators and Controls

Control buttons	Silence, Reset, Resound, Investigate; More Information; Menu	
Event scrolling and menu access buttons	Up (1); Down (2); Accept (3); Abort (4)	
Liquid Crystal Display	Two lines x 40 characters, backlit	
Number of Zonal LED indicators	16	32
Other LED indicators	General Fire, System Energised; Pre-Alarm; Remote Output Activated; Menus Accessed; Disablement; Test; Remote Output Disabled; Silenced; General Fault; System Fault;	

Physical Dimensions

Approx. dimensions of back box (W x H x D)	380 x 235 x 77mm (plastic). Includes 'lip'.	410 x 250 x 80mm (metal)
Approx. dimensions of lid (W x H x D)	380 x 235 x 16mm (plastic)	439 x 274 x 7mm (metal)
Approx. weight (without batteries)	1.9Kg	4.5kg

Cabling Requirements

Type of cable	Fire resistant screened cable, minimum size 1mm ²	
Max. cable length per loop	1km	
Connector blocks	Plug-on type, largest acceptable conductor size 1.5mm ²	
Max. allowable loop impedance (each conductor)	20 !	
Max. cable capacitance	.27µF	

Network Specification

Connection	Via CFP761 network driver card fitted at main panel	Via AFP711 network driver card fitted at main panel
Max. no. of main panels per network	8	8
Max. no of repeaters per non-networked main panel	8	8
Max. cable length per network	1km (main panel network); 500m (repeater network)	

PC/Printer Interface

PC connection	Via main panel RS232 molex connector (lead supplied in XFP507 upload/download software kit)	
Printer connection	Not applicable	Via main panel RS232 connector block.

Operating conditions

The components are selected to operate within their specification when the environmental conditions outside the enclosure comply with class 3k5 of IEC 721-3-3 : 1978. Temperature range:- 5 to +40°C. Maximum relative humidity: 95%